



OWEN 150L

ESPECIFICACIONES TÉCNICAS

- Motor 4 Tiempos enfriado por aire
- Cilindraje 193.2CC.
- Torque 13 NM a 5000 rpm.
- Velocidad máxima 95 Km/h
- Combustible gasolina regular..
- Transmisión 5 velocidades.
- Freno delantero disco ventilado.
- Capacidad del tanque 3.1galones.
- Tablero Digital
- Peso permitido 75 Kg.



MRT
MotorRad Technk

ESTIMADO CLIENTE DE MASESA

Para nuestra organización es razón de satisfacción poder llevar hasta sus manos esta importante herramienta de trabajo.

La intención básica de facilitarle este útil catálogo, es compartir y ampliar el conocimiento que tenemos de los componentes que conforman nuestros modelos MRT.

Una vez alcanzado este objetivo, logramos tener la base necesaria para fortalecer y desarrollar nuestra capacidad de servir a nuestros clientes, razón primordial de nuestra existencia.

A través del uso de este instrumento, Masesa intenta inspirar y motiva un alto nivel de servicio y un auténtico interés por satisfacer los requerimientos de nuestros usuarios.

Con mucho orgullo, esfuerzo y trabajo, Masesa le deja en sus manos esta herramienta.

ÍNDICE

- 5 INDICE GRÁFICO**
- 9 CULATA Y CILINDRO**
Fig. -1
- 10 VALVULAS**
Fig. -2
- 11 TAPADERA DE CARTER Y CARTER**
Fig. -3
- 12 FILTRO CENTRIFUGO Y MOTOR DE ESTARTER**
Fig. -4
- 13 PLANTA Y CLUTCH**
Fig. -5
- 14 TRANSMISION**
Fig. -6
- 15 TRANSMISION, CIGÜEÑAL Y PISTON**
Fig. -7
- 16 SELECTOR DE CAMBIOS, CARBURADOR Y PALANCAS**
Fig. -8
- 17 SISTEMA ELECTRICO, SISTEMA DE PRESION Y SILVIN**
Fig. -9
- 18 MANGOS, SWITCH Y TABLERO**
Fig. -10
- 19 T DE BARRAS, TIMON Y LODERA DELANTERA**
Fig. -11
- 20 BARRAS Y LODERA DELANTERA**
Fig. -12
- 21 LLANTA TRASERA Y FRENO DELANTERO**
Fig. -13
- 22 FRICCIONES**
Fig. -14
- 23 TANQUE DE GASOLINA, COBERTORES Y SILLON**
Fig. -15
- 24 PARRILLAS TRASERAS, FILTRO DE AIRE Y BATERIA**
Fig. -16
- 25 ESCAPE, PATA DOBLE Y MULETA**
Fig. -17
- 26 MONSHOCK Y LODERAS**
Fig. -18
- 27 PIDEVIAS Y STOP**
Fig. -19
- 28 SISTEMA ELECTRICO**
Fig. -20
- 29 CHASIS**
Fig. -21
- 30 REFERENCIAS**
Fig. -22

FIG.1 CULATA Y CILINDRO



FIG. 2 VALVULAS



FIG. 3 TAPADERA DE CARTER Y CARTER



FIG. 4 FILTRO CENTRIFUGO Y MOTOR DE ESTARTER



FIG. 5 PLANTA Y CLUTCH



FIG. 6 TRANSMISION



FIG. 7 TRANSMISION, CIGÜEÑAL Y PISTON

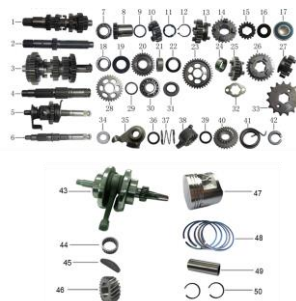

FIG. 8 SELECTOR DE CAMBIOS, CARBURADOR Y PALANCAS



FIG. 9 SISTEMA ELECTRICO, SISTEMA DE PRESION Y SILVIN



FIG. 10 MANGOS, SWITCH Y TABLERO

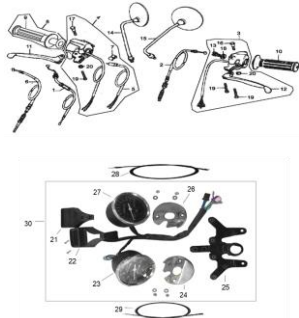

FIG. 11 T DE BARRAS, TIMON Y LODERA DELANTERA

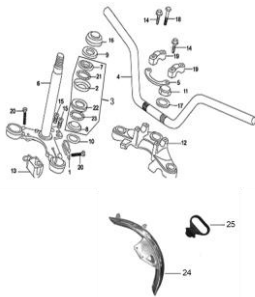

FIG. 12 BARRAS Y LLANTA DELANTERA



FIG.13 LLANTA TRASERA Y FRENO DELANTERO

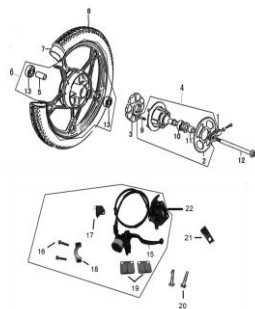

FIG. 14 FRICCIONES

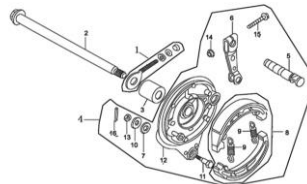

FIG. 15 TANQUE DE GASOLINA, COBERTORES Y SILLON



FIG. 16 PARRILLAS TRASERAS, FILTRO DE AIRE Y BATERIA

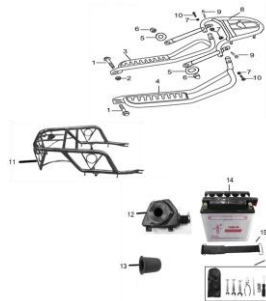

FIG. 17 ESCAPE, PATA DOBLE Y MULETA

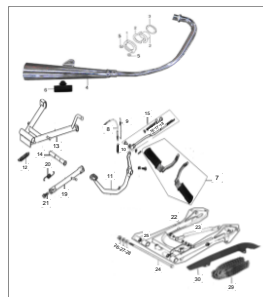

FIG. 18 MONOSHOCK Y LODERAS

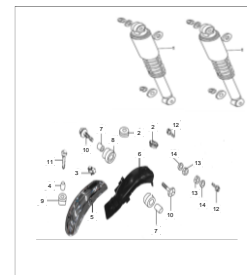

FIG.19 PIDEVIAS Y STOP

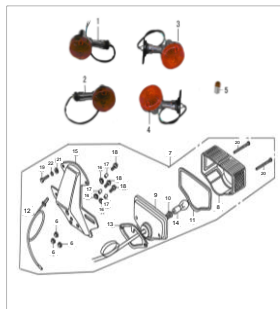

FIG. 20 SISTEMA ELECTRICO

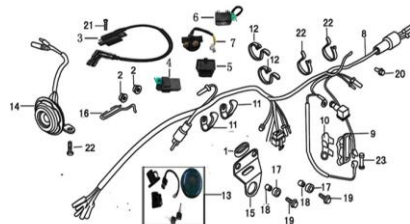

FIG. 21 CHASIS

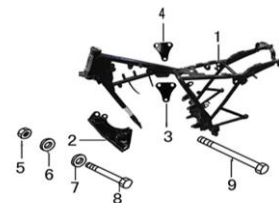
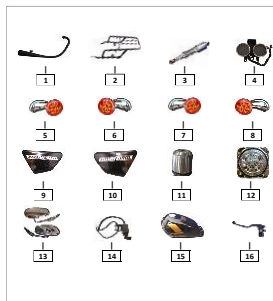

FIG. 22 REFERENCIAS





NO.	AL TERNO	CÓDIGO	DESCRIPCION	CANT.	REF.
1	-	OWL1500 1-01MT	CULATA	1	-
2	-	OWL1500 1-02MT	TAPADERA DE CULATA	1	-
3	-	OWL1500 1-03MT	CILINDRO SOLO	1	-
4	-	OWL1500 1-04MT	EMPAQUE DE CULATA	1	-
5	-	OWL1500 1-05MT	EMPAQUE DE CILINDRO	1	-
6	-	OWL1500 1-06MT	EMPAQUE DE TAPADERA DE CULATA	1	-
7	-	OWL1500 1-07MT	MANIFULL	1	-
8	-	OWL1500 1-08MT	GUIA	1	-
9	-	OWL1500 1-09MT	ARANDELA DE CULATA	1	-
10	-	OWL1500 1-10MT	GUIAS DE CULATA	4	-
11	-	OWL1500 1-11MT	BUJIA	1	-
12	-	OWL1500 1-12MT	TORNILLO M8x73	1	-



NO.	ALTERNO	CÓDIGO	DESCRIPCION	CANT.	REF.
1	-	OWL15002-02MT	VALVULA DE ADMISION	1	-
2	-	OWL15002-03MT	VALVULA DE ESCAPE	1	-
3	-	OWL15002-01MT	BANCADA DE BALANCINES	1	-
4	-	OWL15002-22MT	SOPORTE DE BARRA	1	-
5	-	OWL15002-17MT	VARILLAS DE TIEMPO	2	-
6	-	OWL15002-04MT	CUÑAS DE VALVULAS	2	-
7	-	OWL15002-05MT	ASIENTO DE VALVULAS	2	-
8	-	OWL15002-09MT	RESORTE DE VALVULAS EXTERNO	2	-
9	-	OWL15002-10MT	RESORTE DE VALVULAS INTERNO	2	-
10	-	OWL15002-06MT	RETENENDORES DE VALVULAS	2	-
11	-	OWL15002-07MT	ARANDELA	2	-
12	-	OWL15002-08MT	ARANDELA	2	-
13	-	OWL15002-11MT	EJE DE LEVAS	1	-
14	-	OWL15002-12MT	ARANDELA	1	-
15	-	OWL15002-13MT	PASADOR DE EJE DE LEVAS	1	-
16	-	OWL15002-14MT	ORING	1	-
17	-	OWL15002-15MT	RESORTE	2	-
18	-	OWL15002-16MT	TOPE DE EJE DE LEVAS	1	-
19	-	OWL15002-21MT	ARANDELA	1	-
20	-	OWL15002-20MT	ORQUETA INFERIOR	1	-
21	-	OWL15002-19MT	EJE DE BALANCINES	1	-
22	-	OWL15002-18MT	ORING	1	-



NO.	ALTERNO	CÓDIGO	DESCRIPCION	CANT.	REF.
1	-	OWL15003-01MT	VARILLA DE NIVEL DE ACEITE	1	-
2	-	OWL15003-02MT	TAPADERA DE CARTER RH	1	-
3	-	OWL15003-03MT	EMPAQUE DE TAPADERA DE CARTER RH	1	-
4	-	OWL15003-04MT	ORING 18x3.5	1	-
5	-	OWL15003-05MT	RETENEDOR 16x28x7	1	-
6	-	OWL15003-06MT	GUIAS DE CARTER	6	-
7	-	OWL15003-07MT	RETENEDOR 6.5x14.5x7	1	-
8	-	OWL15003-08MT	GUSANO DE ASIPIROMETRO	1	-
9	-	OWL15003-09MT	VARILLA DE CLUTCH	1	-
10	-	OWL15003-10MT	ORING	1	-
11	-	OWL15003-11MT	RESORTE	1	-
12	-	OWL15003-12MT	BASE DE VARILLA DE CLUTCH	1	-
13	-	OWL15004-01MT	CARTER LH	1	-
14	-	OWL15004-02MT	ESPARRAGO B	2	-
15	-	OWL15004-03MT	ESPARRAGO A	1	-
16	-	OWL15004-05MT	CARTER RH	1	-
17	-	OWL15004-06MT	EMPAQUE DE CARTER	1	-
18	-	OWL15004-07MT	RETENEDOR 14x28x7	1	-
19	-	OWL15004-18MT	COJINETE	1	-
20	-	OWL15004-08MT	AJUSTE DE CABLE DE CLUTCH	1	-
21	-	OWL15004-09MT	GUIAS DE CARTER	6	-
22	-	OWL15004-10MT	PIN	1	-
23	-	OWL15004-11MT	ORING	1	-
24	-	OWL15004-12MT	ARANADELA TORNILLO DRENAJE	1	-
25	-	OWL15004-13MT	TORNILLO DE DRENAJE	1	-
26	-	OWL15004-14MT	FILTRO DE ACEITE CEDAZO	1	-
27	-	OWL15004-15MT	RESOETE DE FILTRO	1	-
28	-	OWL15004-16MT	ORING	1	-
29	-	OWL15004-17MT	TAPON DE FILTRO DE ACEITE	1	-

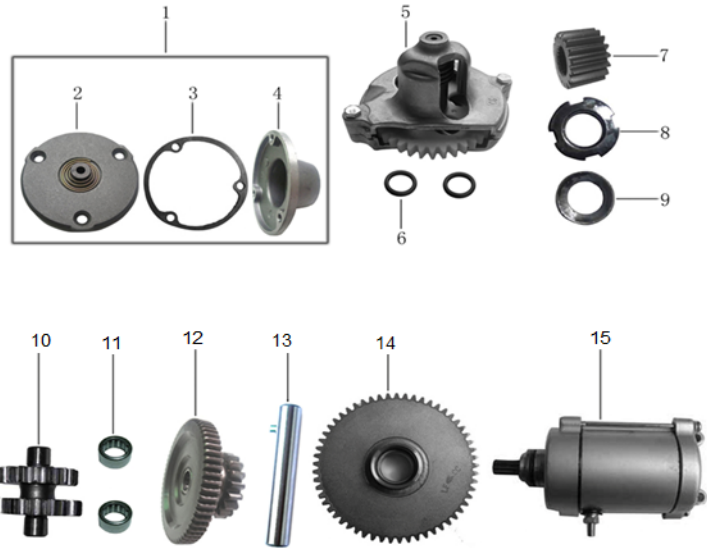

NO.	ALTERNO	CÓDIGO	DESCRIPCION	CANT.	REF.
1	-	OWL15005-01MT	FILTRO CENTRIFUGO	1	-
2	-	OWL15005-02MT	TAPADERA DE FILTRO CENTRIFUGO	1	-
3	-	OWL15005-03MT	EMPAQUE DE FILTRO CENTRIFUGO	1	-
4	-	OWL15005-04MT	TAPADERA DE FILTRO CENTRIFUGO	1	-
5	-	OWL15005-05MT	BOMBA DE ACEITE	1	-
6	-	OWL15005-06MT	ORING DE BOMBA DE ACEITE	1	-
7	-	OWL15005-07MT	ENGRANAJE DE BOMBA	1	-
8	-	OWL15005-08MT	TUERCA DE BOMBA	1	-
9	-	OWL15005-09MT	ARANDELA	1	-
10	-	OWL15006-01MT	ENGRANAJE DE ESTARTER	1	-
11	-	OWL15006-02MT	COJINETE DE PINES	1	-
12	-	OWL15006-03MT	ENGRANAJE DE ESTARTER	1	-
13	-	OWL15006-04MT	PIN DE ESTARTER	1	-
14	-	OWL15006-05MT	ENGRANAJE DE ESTARTER	1	-
15	-	OWL15006-06MT	MOTOR DE ESTARTER	1	-



NO.	ALTERNO	CÓDIGO	DESCRIPCION	CANT.	REF.
1	-	OWL15007-01MT	CLUTCH DE ESTARTER	1	-
2	-	OWL15007-02MT	VOLANTE	1	-
3	-	OWL15007-03MT	TORNILLO DE MAGNETO	1	-
4	-	OWL15007-04MT	PLANTA	1	-
5	-	OWL15007-05MT	EMPAQUE DE VOLANTE	1	-
6	-	OWL15007-06MT	TAPADERA DE PLANTA	1	-
7	-	OWL15007-07MT	RETENEDOR 50x34x7	1	-
8	-	OWL15007-08MT	CLIP DE MAGNETO	1	-
9	-	OWL15007-09MT	SENSOR INDICADOR DE VELOCIDADES	1	-
10	-	OWL15007-10MT	ORING DE TAPON DE TIEMPO	1	-
11	-	OWL15007-17MT	ORING M13.8x2.5	1	-
12	-	OWL15007-11MT	TAPON DE TIEMPO	1	-
13	-	OWL15007-12MT	ORING TAPON DE TIEMPO	1	-
14	-	OWL15007-13MT	TAPADERA LH	1	-
15	-	OWL15007-14MT	ORING 63x3	1	-
16	-	OWL15007-15MT	TAPADERA DE ESTARTER	1	-
17	-	OWL15007-16MT	TAPADERA DE ESPROCKET	1	-
18	-	OWL15008-01MT	CANASTA DE CLUTCH COMPLETA	1	-
19	-	OWL15008-02MT	CANASTA DE CLUTCH	1	-
20	-	OWL15008-03MT	BASE CANASTA DE CLUTCH	1	-
21	-	OWL15008-04MT	BASE 1 CANASTA DE CLUTCH	1	-
22	-	OWL15008-05MT	DISCOS DE CLUTCH DE FIBRA	5	-
23	-	OWL15008-06MT	DISCO DE CLUTCH METAL	4	-
24	-	OWL15008-07MT	BASE 2 CANASTA DE CLUTCH	1	-
25	-	OWL15008-08MT	RESORTE CANASTA DE CLUTCH	4	-
26	-	OWL15008-09MT	PLATO CANASTA DE CLUTCH	1	-
27	-	OWL15008-10MT	ARANDELA CANASTA DE CLUTCH	1	-
28	-	OWL15008-11MT	EJE DE CANASTA	1	-
29	-	OWL15008-12MT	PIN CANASTA DE CLUTCH	1	-
30	-	OWL15008-13MT	COJIENTE 6001	1	-



NO.	ALTERNO	CÓDIGO	DESCRIPCION	CANT.	REF.
1	-	OWL15010-04MT	EJE SECUNDARIO	1	-
2	-	OWL15010-12MT	EJE PRINCIPAL	1	-
3	-	OWL15010-01MT	EJE PRIMARIO	1	-
4	-	OWL15010-13MT	CONTRAEJE	1	-
5	-	OWL15010-14MT	EJE DE ARRANQUE COMPLETO	1	-
6	-	OWL15010-15MT	EJE DE ARRANQUE	1	-
7	-	OWL15010-02MT	COJINETE 6006	1	-
8	-	OWL15010-16MT	ENGRANAJE	1	-
9	-	OWL15010-17MT	ARANDELA	1	-
10	-	OWL15010-18MT	TERCER EJE	1	-
11	-	OWL15010-19MT	ARANDELA DE EJE PRINCIPAL	1	-
12	-	OWL15010-20MT	CLIP	1	-
13	-	OWL15010-21MT	CUARTO ENGRANAJE	1	-
14	-	OWL15010-22MT	RUEDA DELANTERA DE EJE PRINCIPAL	1	-
15	-	OWL15010-23MT	SEGUNDA RUEDA DELANTERA DE EJE	1	-
16	-	OWL15010-24MT	ARANDELA	1	-
17	-	OWL15010-03MT	COJINETE 6202	1	-
18	-	OWL15010-25MT	COJINETE DE AGUJAS	1	-
19	-	OWL15010-26MT	ARANDELA	1	-
20	-	OWL15010-27MT	ENGRANAJE DE ARRANQUE	1	-
21	-	OWL15010-28MT	BUSHING DE EJE DE ARRANQUE	1	-
22	-	OWL15010-29MT	ARANDELA	1	-
23	-	OWL15010-30MT	ENGRANAJE DE CONTRAEJE	1	-
24	-	OWL15010-31MT	BUSHING	1	-
25	-	OWL15010-32MT	ENGRANAJE	1	-
26	-	OWL15010-33MT	EJE DE TRANSMISION	1	-
27	-	OWL15010-34MT	ENGRANAJE	1	-
28	-	OWL15010-35MT	EJE SECUNDARIO	1	-
29	-	OWL15010-36MT	ARANDELA	1	-
30	-	OWL15010-06MT	COJINETE 6204	1	-
31	-	OWL15010-07MT	RETENEDOR 20x34x7	1	-

TRANSMISION, CIGÜEÑAL Y PISTON



NO.	AL TERNO	CÓDIGO	DESCRIPCION	CANT.	REF.
32	-	OWL15010-09MT	SE GURO DE ESPROCKET	1	-
33	-	OWL15010-08MT	ESPROCKET DELANTERO	1	-
34	-	OWL15010-37MT	ARANDELA	1	-
35	-	OWL15010-38MT	GUIA	1	-
36	-	OWL15010-39MT	ARANDELA	1	-
37	-	OWL15010-40MT	RESORTE DE EJE DE ARRANQUE	1	-
38	-	OWL15010-41MT	CARRACA	1	-
39	-	OWL15010-42MT	ARANDELA DEL EJE DE ARRANQUE I	1	-
40	-	OWL15010-43MT	ENGRANAJE DE ARRANQUE	1	-
41	-	OWL15010-44MT	RESORTE DE TORSION DE ARRANQUE	1	-
42	-	OWL15010-45MT	SE GURO	1	-
43	-	OWL15009-01MT	CIGÜEÑAL	1	-
44	-	OWL15009-02MT	CÓJINETE	1	-
45	-	OWL15009-03MT	CUÑA DE CIGÜEÑAL	1	-
46	-	OWL15009-04MT	ENGRANAJE	1	-
47	-	OWL15009-05MT	PISTON	1	-
48	-	OWL15009-06MT	ANILLOS DE PISTON	1	-
49	-	OWL15009-07MT	PASADOR DE PISTON	1	-
50	-	OWL15009-08MT	SE GUROS DE PISTON	2	-

FIG. 8

SELECTRO DE CAMBIOS, CARBURADOR Y PALANCAS

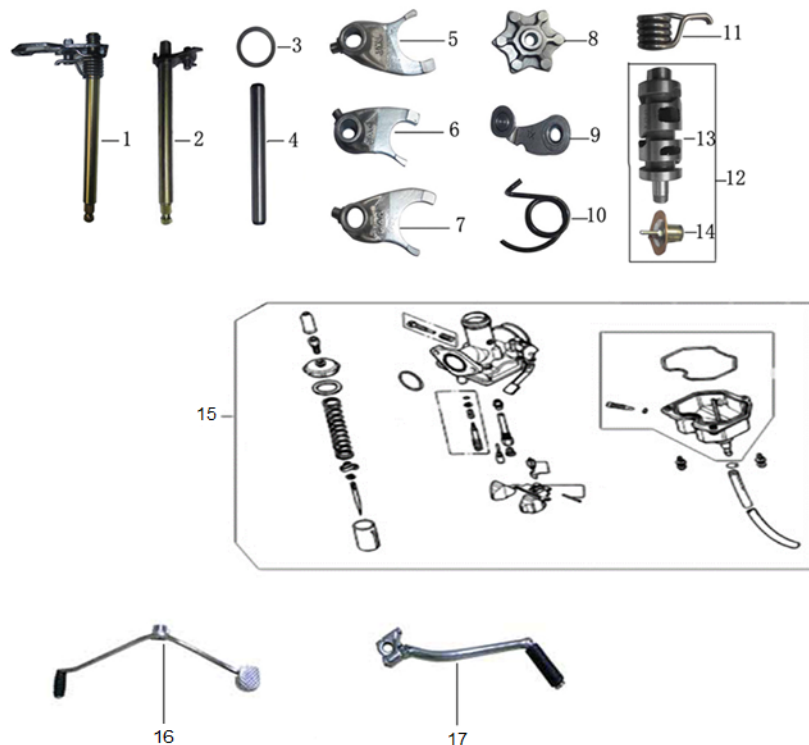

NO.	AL TERNO	CÓDIGO	DESCRIPCION	CANT.	REF.
1	-	OWL15011-01MT	EJE DE VELOCIDADES	1	-
2	-	OWL15011-02MT	EJE DE CAMBIOS	1	-
3	-	OWL15011-03MT	ARANDELA DE CAMBIOS	1	-
4	-	OWL15011-03MT	EJE DE ORQUETAS	1	-
5	-	OWL15011-04MT	ORQUETA 3	1	-
6	-	OWL15011-05MT	ORQUETA 2	1	-
7	-	OWL15011-06MT	ORQUETA 1	1	-
8	-	OWL15011-07MT	ESTRELLA DE CAMBIOS	1	-
9	-	OWL15011-08MT	TOPE DE VELOCIDADES	1	-
10	-	OWL15011-09MT	RESORTE DE CAMBIOS	1	-
11	-	OWL15011-10MT	RESORTE	1	-
12	-	OWL15011-11MT	TAMBOR DE CAMBIOS	1	-
13	-	OWL15011-10MT	SELECTOR DE VELOCIDADES	1	-
14	-	OWL15011-11MT	TOPE SELECTOR DE VELOCIDADES	1	-
15	-	OWL15012-01MT	CARBURADOR	1	-
16	-	OWL15011-02MT	PATA DE VELOCIDADES	1	-
17	-	OWL15010-11MT	PATA DE ARRANQUE	1	-

FIG. 9

SISTEMA ELECTRICO, SISTEMA DE PRESION Y SILVIN

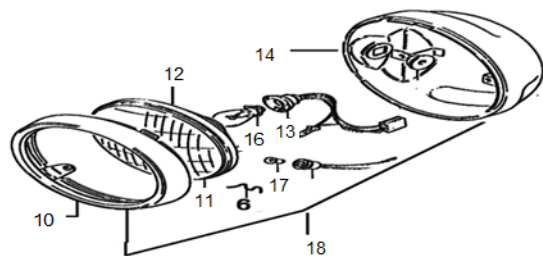

NO.	ALTERNO	CÓDIGO	DESCRIPCION	CANT.	REF.
1	-	OWL15013-01MT	REGULADOR DE VOLTAJE	1	-
2	-	OWL15013-02MT	CDI	1	-
3	-	OWL15013-03MT	BOBINA DE ALTA	1	-
4	-	OWL15013-04MT	RELAY DE ESTARTER	1	-
5	-	OWL15014-01MT	VALVULA DE AIRE	1	-
6	-	OWL15014-02MT	MANGUERA DE AIRE	1	-
7	-	OWL15014-03MT	MANGUERA DE AIRE	1	-
8	-	OWL15014-04MT	MANGUERA DE AIRE	1	-
9	-	OWL15014-05MT	MANGUERA DE ACEITE	1	-
10	-	OWL15015-01MT	ARO DE SILVIN	1	-
11	-	OWL15015-02MT	SILVIN SOLO	1	-
12	-	OWL15015-03MT	SILVIN	1	OWL15015-0901MT
13	-	OWL15015-04MT	SOCKET DE SILVIN	1	-
14	-	OWL15015-05MT	KEIS DE SILVIN	1	-
15	-	OWL15015-06MT	SEGURO DE SILVIN	1	-
16	-	OWL15015-07MT	BOMBILLA DE SILVIN	1	-
17	-	OWL15015-08MT	BOMBILLA LUZ MEDIA	1	-
18	-	OWL15015-09MT	SILVIN COMPLETO	1	-

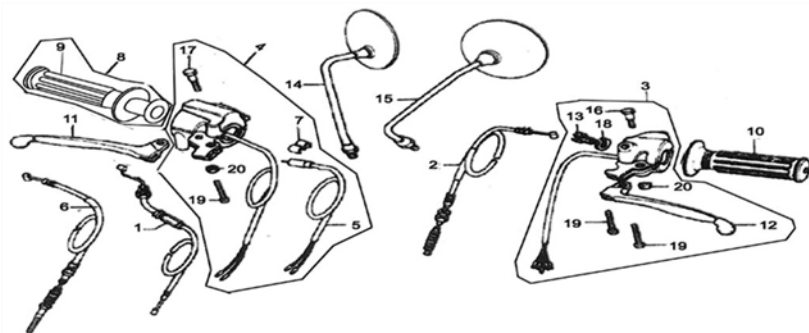

NO.	ALTERNO	CÓDIGO	DESCRIPCION	CANT.	REF.
1	-	OWL15016-01MT	CABLE DE GASOLINA	1	-
2	-	OWL15016-02MT	CABLE DE CLUTCH	1	-
3	-	OWL15016-03MT	SWITCH LH	1	-
4	-	OWL15016-04MT	SWITCH RH	1	-
5	-	OWL15016-05MT	SWITCH FRENO DELANTERO	1	-
6	-	OWL15016-06MT	CABLE FRENO DELANTERO	1	-
7	-	OWL15016-07MT	CLIP	1	-
8	-	OWL15016-08MT	MANGO DE GASOLINA	1	-
9	-	OWL15016-09MT	MANGO RH	1	-
10	-	OWL15016-10MT	MANGO IZQUIERDO	1	-
11	-	OWL15016-11MT	MANECILLA DE FRENO	1	-
12	-	OWL15016-12MT	MANECILLA DE CLUTCH	1	OWL15016-21MT
13	-	OWL15016-13MT	TORNILLO DE AJUSTE	1	-
14	-	OWL15016-14MT	ESPEJO RH	1	OWL15016-22MT
15	-	OWL15016-15MT	ESPEJO LH	1	OWL15016-22MT
16	-	OWL15016-16MT	TORNILLO DE MANECILLA	1	-
17	-	OWL15016-17MT	TORNILLO DE MANECILLA	1	-
18	-	OWL15016-18MT	CUNA	1	-
19	-	OWL15016-19MT	TORNILLO	1	-
20	-	OWL15016-20MT	TUERCA M6	1	-
21	-	OWL15017-01MT	COBERTOR DE TABLERO	1	-
22	-	OWL15017-02MT	INDICADOR DE VELOCIDADES	1	-
23	-	OWL15017-03MT	RELOJ ODOMETRO	1	-
24	-	OWL15017-04MT	BASE RELOJ ODOMETRO	1	-
25	-	OWL15017-05MT	BASE DE TABLERO	1	-
26	-	OWL15017-06MT	RELOJ TACOMETRO	1	-
27	-	OWL15017-07MT	BASE DE TACOMETRO	1	-
28	-	OWL15017-08MT	CABLE DE TACOMETRO	1	-
29	-	OWL15017-09MT	CABLE DE ASPIROMETRO	1	-
30	-	OWL15017-10MT	RELOJ COMPLETO	1	OWL15017-12MT

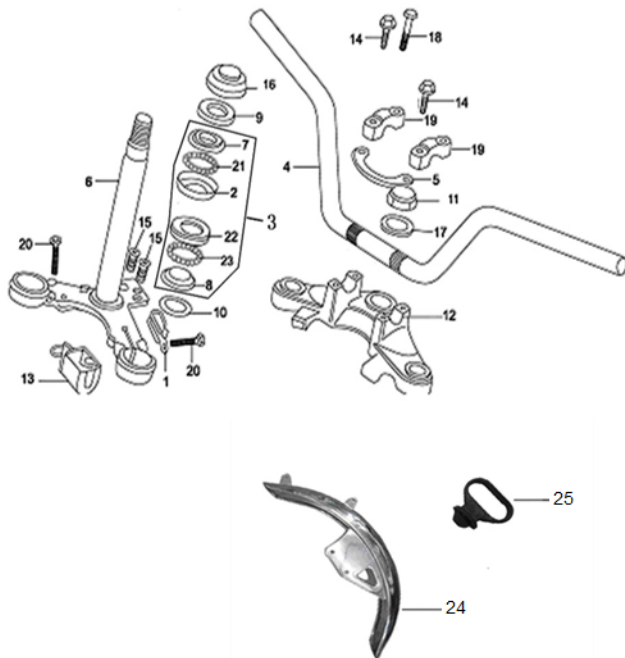

NO.	ALTERNO	CÓDIGO	DESCRIPCION	CANT.	REF.
1	-	OWL15018-01MT	GUIA DE CABLES	1	-
2	-	OWL15018-02MT	CUNA SUPERIOR	1	-
3	-	OWL15018-03MT	KIT CUNAS DE TIMON	1	-
4	-	OWL15018-04MT	TIMON	1	-
5	-	OWL15018-05MT	SEGURO DE TIMON	1	-
6	-	OWL15018-06MT	T DE BARRAS	1	-
7	-	OWL15018-07MT	COJINETE DE TIMON	1	-
8	-	OWL15018-08MT	CUNA INFERIOR	1	-
9	-	OWL15018-09MT	CUNA	1	-
10	-	OWL15018-10MT	CUNA INFERIOR	1	-
11	-	OWL15018-11MT	TUERCA DE TIMON	1	-
12	-	OWL15018-12MT	BASE DE TIMON	1	-
13	-	OWL15018-13MT	CANDADO DE TIMON	1	-
14	-	OWL15018-14MT	TORNILLO M8x35	4	-
15	-	OWL15018-15MT	TORNILLO M6x12	2	-
16	-	OWL15018-16MT	TORNILLO DE TIMON	2	-
17	-	OWL15018-17MT	ARANDELA	2	-
18	-	OWL15018-18MT	TORNILLO	2	-
19	-	OWL15018-19MT	BASES DE TIMON	2	-
20	-	OWL15018-20MT	TORNILLO M8x38	2	-
21	-	OWL15018-21MT	MUNICIONES	1	-
22	-	OWL15018-22MT	CUNA	1	-
23	-	OWL15018-23MT	MUNICIONES	1	-
24	-	OWL15019-01MT	LODERA DELANTERA	1	-
25	-	OWL15019-02MT	GUIA DE CABLE	1	-

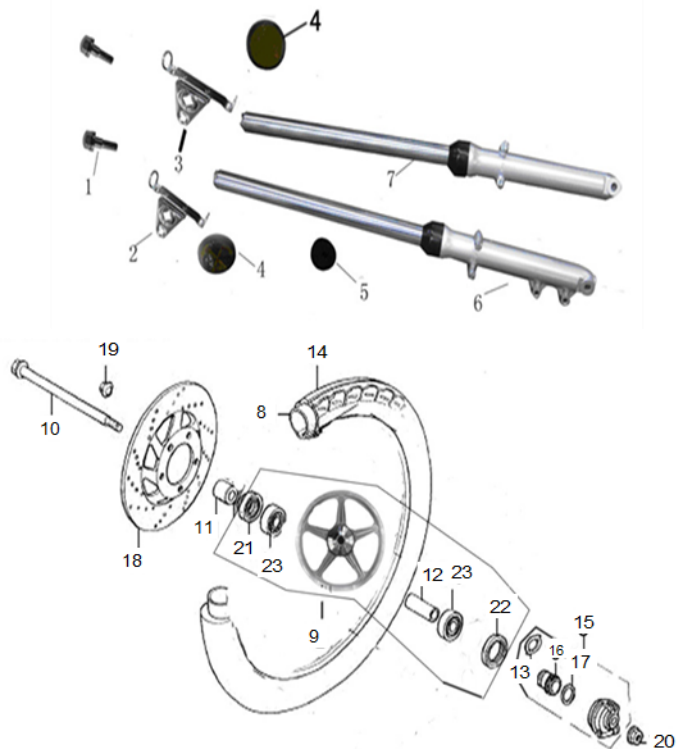

NO.	ALTERNO	CÓDIGO	DESCRIPCION	CANT.	REF.
1	-	OWL15020-01MT	TORNILLO DE BARRA	1	-
2	-	OWL15020-02MT	BASE DE SILVIN LH	1	-
3	-	OWL15020-03MT	BASE DE SILVIN RH	1	-
4	-	OWL15020-04MT	REFLECTOR DELANTERO	1	-
5	-	OWL15020-05MT	REFLECTOR DELANTERO	1	-
6	-	OWL15020-06MT	BARRA LH	1	-
7	-	OWL15020-07MT	BARRA RH	1	-
8	-	OWL15021-01MT	TUBO DELANTERO	1	-
9	-	OWL15021-02MT	ARO DELANTERO	1	-
10	-	OWL15021-03MT	EJE DELANTERO	1	-
11	-	OWL15021-04MT	BUSHING ARO DELANTERO	1	-
12	-	OWL15021-05MT	BUSHING ARO DELANTERO	1	-
13	-	OWL15021-06MT	COJINETE	1	-
14	-	OWL15021-07MT	LLANTA DELANTERA	1	-
15	-	OWL15021-08MT	CAJA DE ENGRANAJE	1	-
16	-	OWL15021-09MT	ENGRANAJE DE ASPIROMETRO	1	-
17	-	OWL15021-10MT	ARANDELA	1	-
18	-	OWL15021-11MT	DISCO FRENO DELANTERO	1	-
19	-	OWL15021-12MT	TUERCA	1	-
20	-	OWL15021-13MT	TUERCA EJE DELANTERO	1	-
21	-	OWL15021-14MT	RETENEDOR 23x37x7	1	-
22	-	OWL15021-15MT	GUARDAPOLVO	1	-
23	-	OWL15021-16MT	COJINETE 6301	2	-

LLANTA TRASERA Y FRENO DELANTERO

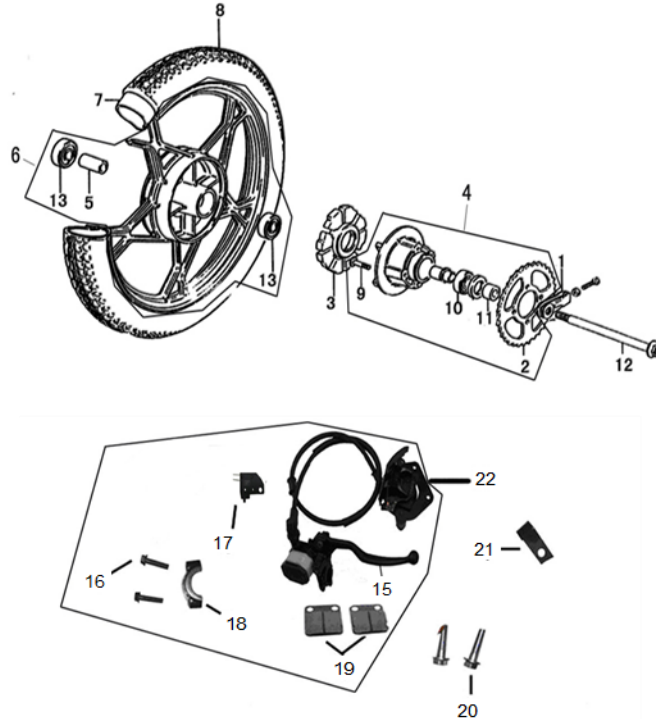

NO.	ALTERNO	CÓDIGO	DESCRIPCION	CANT.	REF.
1	-	OWL15022-01MT	TENSOR DE CADENA	1	-
2	-	OWL15022-02MT	ESPROCKET TRASERO	1	-
3	-	OWL15022-03MT	HULES DE MASA	1	-
4	-	OWL15022-04MT	PORTAESPORCKET COMPLETO	1	-
5	-	OWL15022-05MT	BUSHING DE ARO	1	-
6	-	OWL15022-06MT	ARO TRASERO COMPLETO	1	-
7	-	OWL15022-07MT	TUBO DE LLANTA	1	-
8	-	OWL15022-08MT	LLANTA TRASERA	1	-
9	-	OWL15022-09MT	TORNILLO DE ESPROCKET	4	-
10	-	OWL15022-10MT	RETENEDOR	1	-
11	-	OWL15022-11MT	BUSHING ESPROCKET TRASERO	1	-
12	-	OWL15022-12MT	EJE LLANTA TRASERA	1	-
13	-	OWL15022-13MT	COJINETE RH	1	-
14	-	OWL15022-13-01MT	COJINETE LH	1	-
15	-	OWL15023-01MT	MANECILLA DE FRENO	1	-
16	-	OWL15023-02MT	TORNILLO DE MANECILLA	1	-
17	-	OWL15023-03MT	SWITCH FRENO DELANTERO	1	-
18	-	OWL15023-04MT	BASE DE MANECILLA	1	-
19	-	OWL15023-05MT	PASTILLAS DE FRENO DELANTERO	1	-
20	-	OWL15023-06MT	TORNILLO	1	-
21	-	OWL15023-07MT	SEGURO DE MANGUERA	1	-
22	-	OWL15023-08MT	SISTEMA FRENO DELANTERO	1	-
			llanta trasera y freno delantero		

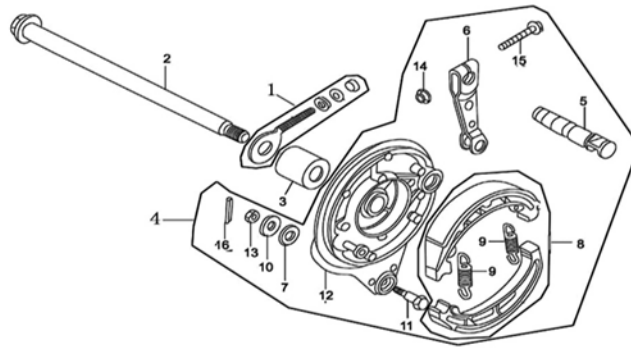

NO.	ALTERNO	CÓDIGO	DESCRIPCION	CANT.	REF.
1	-	OWL15024-01MT	SENSOR CADENA DE TRACCIÓN	1	-
2	-	OWL15024-02MT	EJE LLANTA TRASERA	1	-
3	-	OWL15024-03MT	BUSHING EJE TRASERO	1	-
4	-	OWL15024-04MT	PLATO FRICCIONES COMPLETO	1	-
5	-	OWL15024-05MT	EJE DE FRICCION	1	-
6	-	OWL15024-08MT	BRAZO DE FRICCION	1	-
7	-	OWL15024-07MT	ARANDELA	1	-
8	-	OWL15024-08MT	FRICCIONES TRASERAS	1	-
9	-	OWL15024-09MT	RESORTE DE FRICCION	1	-
10	-	OWL15024-10MT	ARANDELA	1	-
11	-	OWL15024-11MT	TORNILLO PORTA FRICCIONES	1	-
12	-	OWL15024-12MT	PORTA FRICCIONES	1	-
13	-	OWL15024-13MT	TUERCA	1	-
14	-	OWL15024-14MT	TUERCA	1	-
15	-	OWL15024-15MT	TORNILLO	1	-
16	-	OWL15024-16MT	SEGURO	1	-

TANQUE DE GASOLINA, COBERTORES Y SILLON

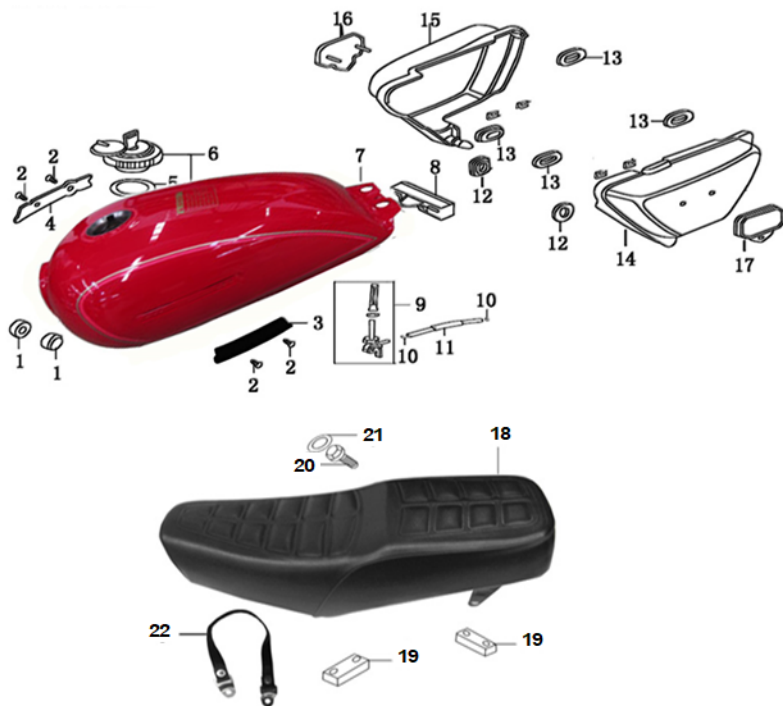

NO.	ALTERNO	CÓDIGO	DESCRIPCION	CANT.	REF.
1	-	OWL15025-01MT	HULES DE TANQUE	1	-
2	-	OWL15025-02MT	TORNILLO M 3.5x20	1	-
3	-	OWL15025-03MT	HULE DE TANQUE LH	1	-
4	-	OWL15025-04MT	HULE DE TANQUE RH	1	-
5	-	OWL15025-05MT	EMPAQUE TAPON DE TANQUE	1	-
6	-	OWL15025-06MT	TAPON TANQUE DE GASOLINA	1	-
7	-	OWL15025-07-01MT	TANQUE DE GASOLINA ROJO	1	OWL15025-07MT
8	-	OWL15025-08MT	HULE DE TANQUE	1	-
9	-	OWL15025-09MT	LLAVE DE GASOLINA	1	-
10	-	OWL15025-10MT	MANGUERA DE GASOLINA	1	-
11	-	OWL15025-11MT	MANGUERA DE GASOLINA	1	-
12	-	OWL15025-12MT	HULE TAPADERA LATERAL	1	-
13	-	OWL15025-13MT	HULE TAPADERA LATERAL	1	-
14	-	OWL15025-14MT	TAPADERA LATERAL LH	1	OWL15025-14MT
15	-	OWL15025-15MT	TAPADERA LATERAL RH	1	OWL15025-15MT
16	-	OWL15025-16MT	COBERTOR RH	1	-
17	-	OWL15025-17MT	COBERTOR LH	1	-
1	-	OWL15026-01MT	SILLON	1	-
2	-	OWL15026-02MT	HULES DE SILLON	1	-
3	-	OWL15026-03MT	TORNILLO DE SILLON	1	-
4	-	OWL15026-04MT	ARANDELA DE SILLON	1	-
5	-	OWL15026-05MT	BANDA	1	-
			tanque cobertores y sillón		

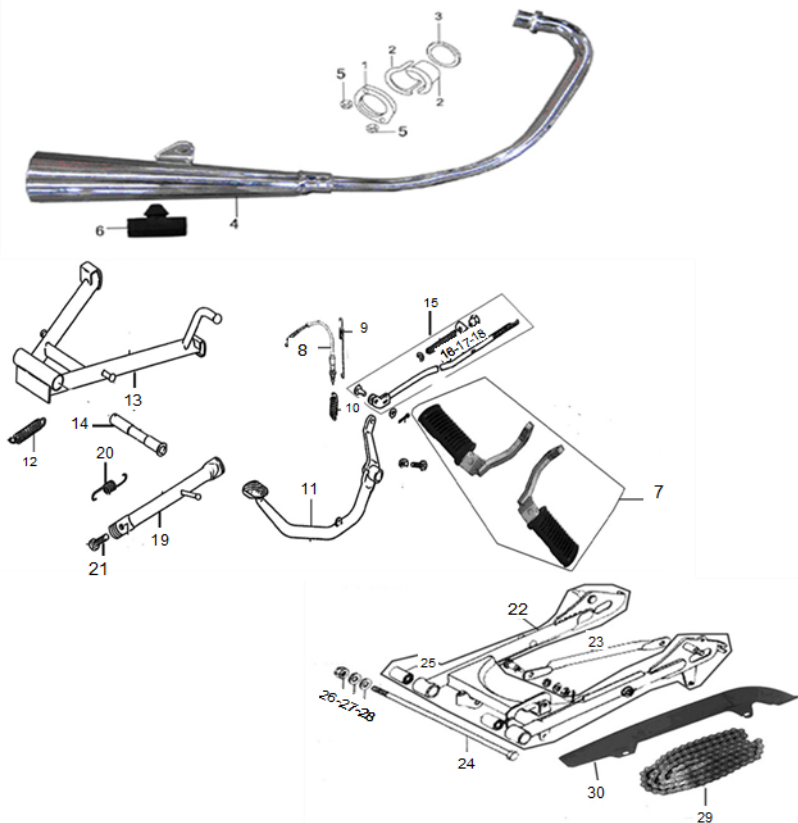

NO.	ALTERNO	CÓDIGO	DESCRIPCION	CANT.	REF.
1	-	OWL15030-01MT	EM PAQUE DE ESCAPE	1	-
2	-	OWL15030-02MT	EM PAQUE BOQUILLA DE ESCAPE	1	-
3	-	OWL15030-03MT	EM PAQUE DE ESCAPE	1	-
4	-	OWL15030-04MT	ESCAPE	1	OWL15030-04MT
5	-	OWL15030-05MT	TORNILLO PUNTA DE ESCAPE	1	-
6	-	OWL15030-06MT	HULE DE ESCAPE	1	-
7	-	OWL15031-01MT	TACOS DE LANTEROS	1	-
8	-	OWL15031-02MT	SWITCH FRENO TRASERO	1	-
9	-	OWL15031-03MT	RESORTE SWITCH DE FRENO	1	-
10	-	OWL15031-04MT	RESORTE PATA DE FRENO	1	-
11	-	OWL15031-05MT	PATA DE FRENO	1	-
12	-	OWL15031-06MT	RESORTE PATA DOBLE	1	-
13	-	OWL15031-07MT	PATA DOBLE	1	-
14	-	OWL15031-08MT	EJE PATA DOBLE	1	-
15	-	OWL15031-09MT	VARILLA DE FRENO	1	-
16	-	OWL15031-10MT	RESORTE DE VARILLA DE FRENO	1	-
17	-	OWL15031-11MT	TOPE VARILLA DE FRENO	1	-
18	-	OWL15031-12MT	TUERCA VARILLA DE FRENO	1	-
19	-	OWL15031-13MT	PATA LATERAL	1	-
20	-	OWL15031-14MT	RESORTE PATA LATERAL	1	-
21	-	OWL15031-15MT	TORNILLO PATA LATERAL	1	-
22	-	OWL15032-01MT	MULETA	1	-
23	-	OWL15032-02MT	ANCLA DE FRENO	1	-
24	-	OWL15032-03MT	EJE DE MULETA	1	-
25	-	OWL15032-04MT	BUSHING DE MULETA	1	-
26	-	OWL15032-05MT	TUERCA DE MULETA	1	-
27	-	OWL15032-06MT	ARANDELA M 12	1	-
28	-	OWL15032-07MT	ARANDELA M 12	1	-
29	-	OWL15032-08MT	CADENA	1	-
30	-	OWL15032-09MT	PROTECTOR DE CADENA	1	-

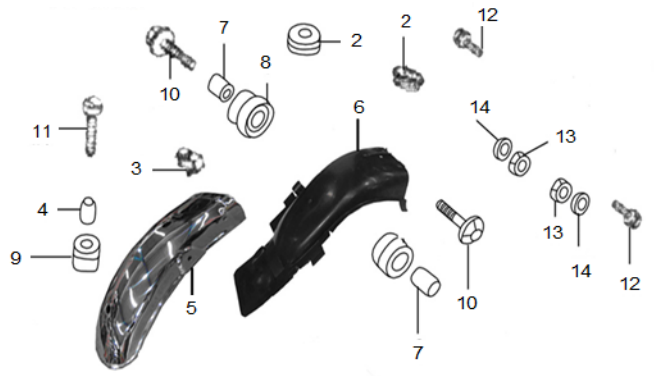
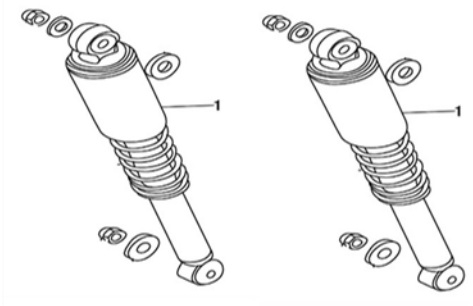

NO.	AL TERNO	CÓDIGO	DESCRIPCION	CANT.	REF.
1	-	OWL15033-01MT	AM ORTIGUADOR TRASERO	2	OWL15033-01MT
2	-	OWL15034-01MT	HULE	2	-
3	-	OWL15034-02MT	HULES DE LODERA	1	-
4	-	OWL15034-03MT	HULES DE LODERA	1	-
5	-	OWL15034-04MT	LODE RA TRASERA M ETAL	1	-
6	-	OWL15034-05MT	LODE RA TRASERA PLASTICA	1	-
7	-	OWL15034-06MT	BUSHING	2	-
8	-	OWL15034-07MT	HULE	2	-
9	-	OWL15034-08MT	HULE BASE DE LODERA	1	-
10	-	OWL15034-09MT	TORNILLO DE LODERA	2	-
11	-	OWL15034-10MT	TORNILLO BASE DE LODERA	1	-
12	-	OWL15034-11MT	TORNILLO M6x20	2	-
13	-	OWL15034-12MT	TUERCA	2	-
14	-	OWL15034-13MT	ARANDELA	2	-

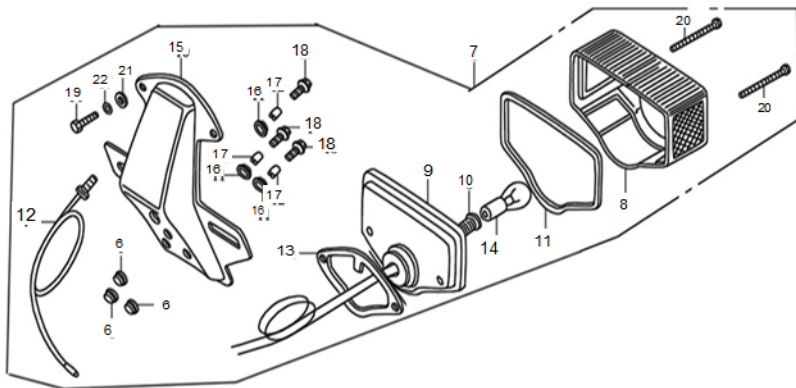

NO.	AL TERNO	CÓDIGO	DESCRIPCION	CANT.	REF.
1	-	OWL15035-01MT	PIDEVIAS FR RH	1	OWL15039-05MT
2	-	OWL15035-02MT	PIDEVIAS FR LH	1	OWL15039-06MT
3	-	OWL15035-03MT	PIDEVIAS RR LH	1	OWL15039-03MT
4	-	OWL15035-04MT	PIDEVIAS RR RH	1	OWL15039-04MT
5	-	OWL15035-05MT	BOMBILLA DE PIDEVIAS	4	-
6	-	OWL15036-01MT	TUERCA M6	3	-
7	-	OWL15036-02MT	STOP COMPLETO	1	-
8	-	OWL15036-03MT	TALCO DE STOP	1	-
9	-	OWL15036-04MT	BASE DE STOP	1	-
10	-	OWL15036-05MT	SOCKET DE BOMBILLA	1	-
11	-	OWL15036-06MT	EMPAQUE DE STOP	1	-
12	-	OWL15036-07MT	CABLE STOP	1	-
13	-	OWL15036-08MT	EMPAQUE	1	-
14	-	OWL15036-09MT	BOMBILLA DE ETOP	1	-
15	-	OWL15036-10MT	BASE DE STOP	1	-
16	-	OWL15036-11MT	HULE	1	-
17	-	OWL15036-12MT	BUSHING	1	-
18	-	OWL15036-13MT	TORNILLO M6x12	1	-
19	-	OWL15036-14MT	TORNILLO M5x12	1	-
20	-	OWL15036-15MT	TORNILLO M4x38	1	-
21	-	OWL15036-16MT	ARANDELA M5	1	-
22	-	OWL15036-17MT	ARANDELA DE PRESSION	1	-
			pidevias y stop		

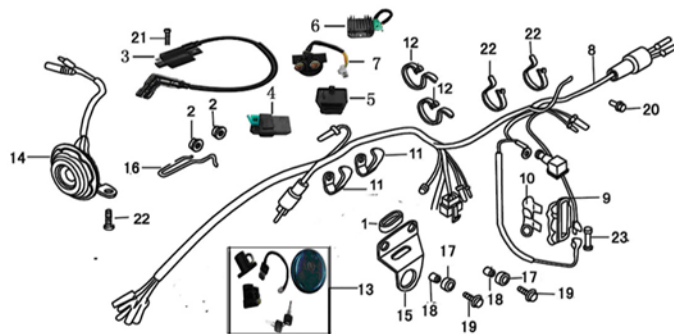

NO.	AL TERNO	CÓDIGO	DESCRIPCION	CANT.	REF.
1	-	OWL15037-01MT	COBERTOR DE SWITCH	1	-
2	-	OWL15037-02MT	TUER C M6	1	-
3	-	OWL15037-03MT	BOBINA DE ALTA	1	-
4	-	OWL15037-04MT	CDI	1	-
5	-	OWL15037-05MT	FLASHER	1	-
6	-	OWL15037-06MT	REGULADOR DE VOLTAJE	1	-
7	-	OWL15037-07MT	RELAY DE E STARTER	1	-
8	-	OWL15037-08MT	ARNES	1	-
9	-	OWL15037-09MT	CAJA FUSIBLE	1	-
10	-	OWL15037-10MT	BASE DE CAJA FUSIBLE	1	-
11	-	OWL15037-11MT	HULE 1	1	-
12	-	OWL15037-12MT	HULE 2	1	-
13	-	OWL15037-13MT	KIT DE SWITCH	1	-
14	-	OWL15037-14MT	BOCINA	1	-
15	-	OWL15037-15MT	BASE SWITCH IGNICION	1	-
16	-	OWL15037-16MT	GUIA DE CABLE	1	-
17	-	OWL15037-17MT	HULE	1	-
18	-	OWL15037-18MT	HULE	1	-
19	-	OWL15037-19MT	TORNILLO	1	-
20	-	OWL15037-20MT	TORNILLO	1	-
21	-	OWL15037-21MT	TORNILLO	1	-
22	-	OWL15037-22MT	HULE	1	-
23	-	OWL15037-23MT	FUSIBLE	1	-

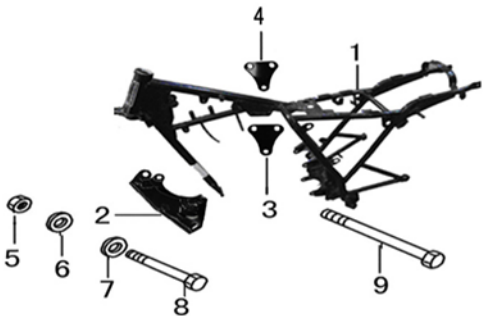

NO.	AL TERNO	CÓDIGO	DESCRIPCION	CANT.	REF.
1	-	OWL15038-01MT	CHASIS	1	-
2	-	OWL15038-02MT	CARGADOR DE MOTOR	1	-
3	-	OWL15038-03MT	CARGADOR DE MOTOR LH	1	-
4	-	OWL15038-04MT	CARGADOR DE MOTOR RH	1	-
5	-	OWL15038-05MT	TUERCA	1	-
6	-	OWL15038-06MT	ARANDELA	1	-
7	-	OWL15038-07MT	ARANDELA	1	-
8	-	OWL15038-08MT	TORNILLO M8x70	1	-
9	-	OWL15038-09MT	TORNILLO M8x115	1	-



1



2



3



4



5



6



7



8



9



10



11



12



13



14



15



16

NO.	ALTERNO	CÓDIGO	DESCRIPCION	CANT.	REF.
1	-	OWL15030-04MT	ESCAPE	1	OWL15030-04MT
2	-	OWL15028-01MT	PARRILLA TRASERA	1	OWL15028-01MT
3	-	OWL15033-01MT	AMORTIGUADOR TRASERO	1	OWL15033-01MT
4	-	OWL15017-12MT	RELOJ COMPLETO - DIGITAL	1	OWL15017-10MT
5	-	OWL15039-05MT	PIDEVIS RR RH LED	1	OWL15035-01MT
6	-	OWL15039-06MT	PIDEVIS RR LH LED	1	OWL15035-02MT
7	-	OWL15039-03MT	PIDEVIS FR RH LED	1	OWL15035-03MT
8	-	OWL15039-04MT	PIDEVIS FR LH LED	1	OWL15035-04MT
9	-	OWL15025-14MT	TAPADERA LATERAL LH	1	OWL15025-14MT
10	-	OWL15025-15MT	TAPADERA LATERAL RH	1	OWL15025-15MT
11	-	OWL15039-11MT	CONTRAPESOS DE TIMOS	2	-
12	-	OWL15015-0901MT	SILVIN LED COMPLETO	1	OWL15015-03MT
13	-	OWL15016-22MT	KIT DE RETROVISORES	1	OWL15016-14MT
14	-	OWL15039-14MT	USB	1	-
15	-	OWL15025-07MT	TANQUE DE GASOLINA NEGRO	1	OWL15025-07-01MT
15	-	OWL15016-21MT	MANECILLA DE CLUTCH COMPLETA	1	OWL15016-12MT



MASESA

M o t o s d e t r a b a j o

PBX: 2324-4400

www.masesa.com |    